

F9J 6G BG				
97 B	F9J	89G7 F-@HC B	85H9	5DDFCJ 98
SS%5	5	8 A 57FC GG: @5HG 5G-B7 CFF97 H	+@- #5	88G
SS%6	6	F98F5K B 5BB B A 98GC B 98 B GC @8 K C F?G	%@#&#5	77G

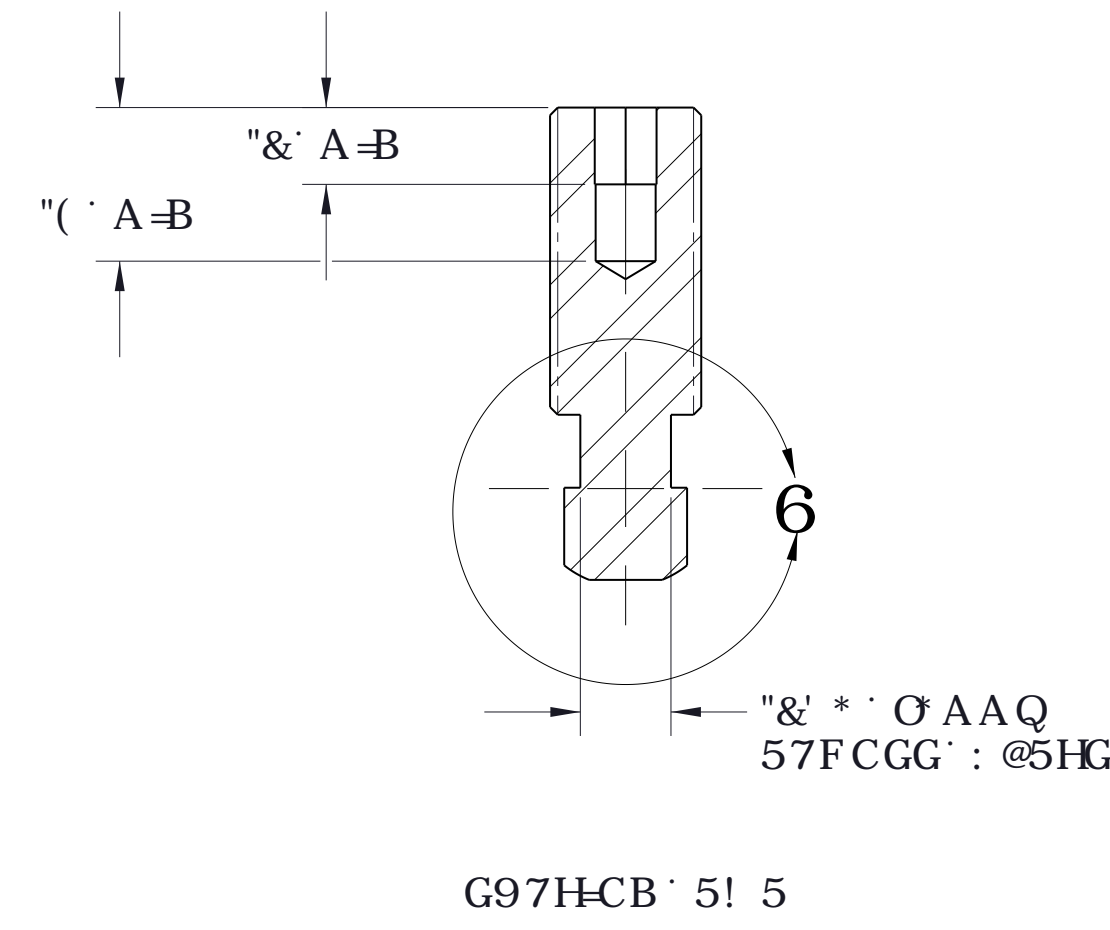
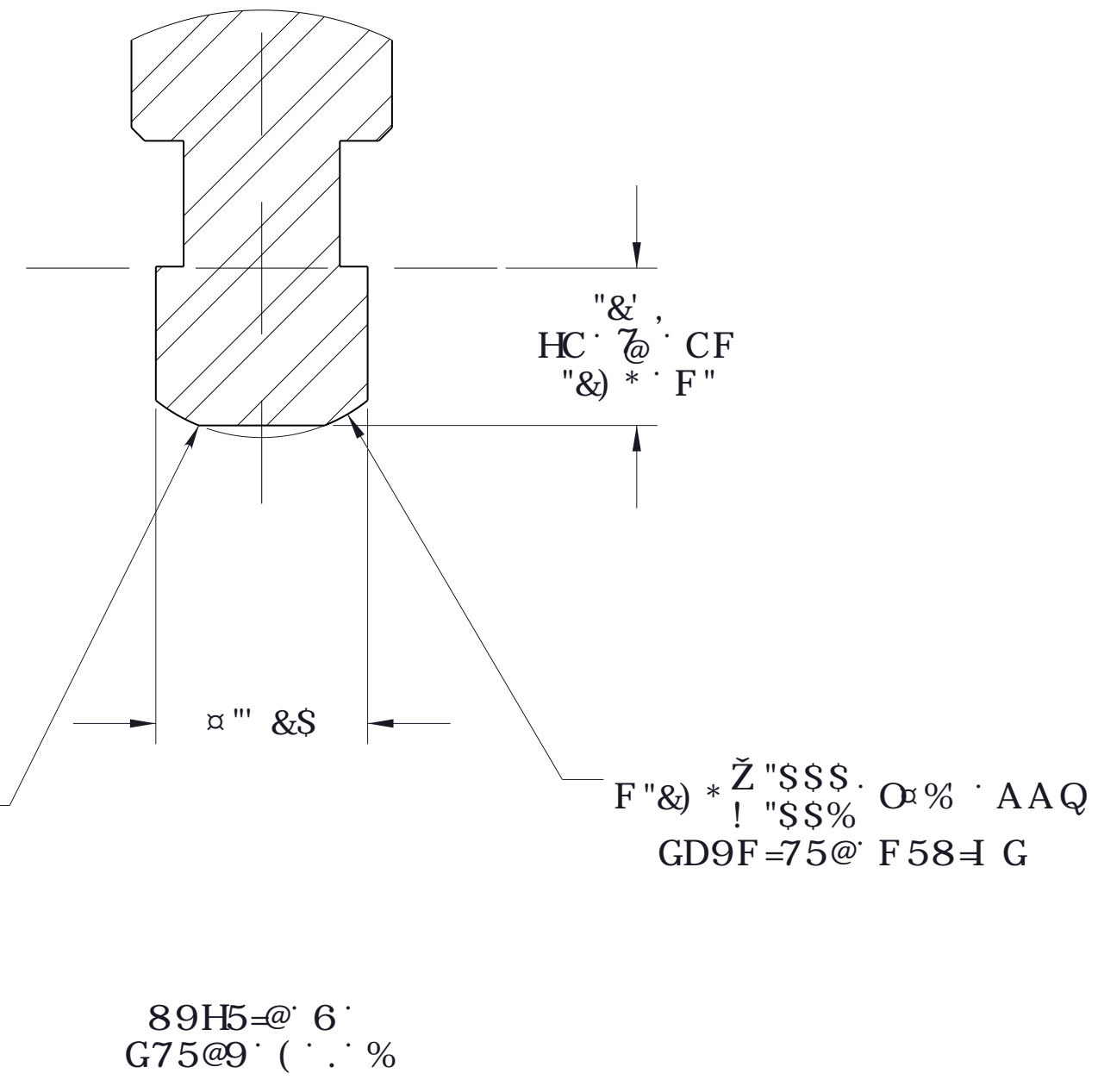
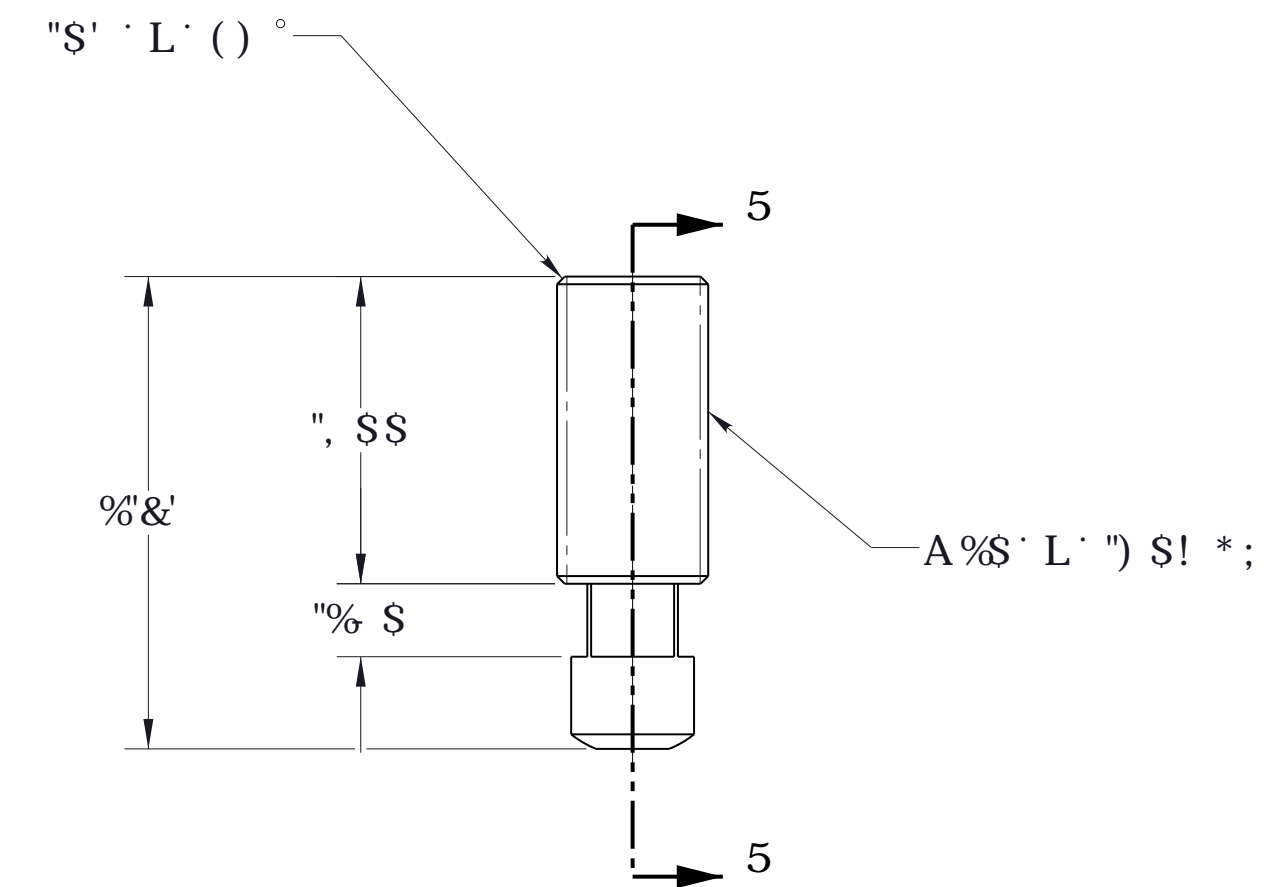
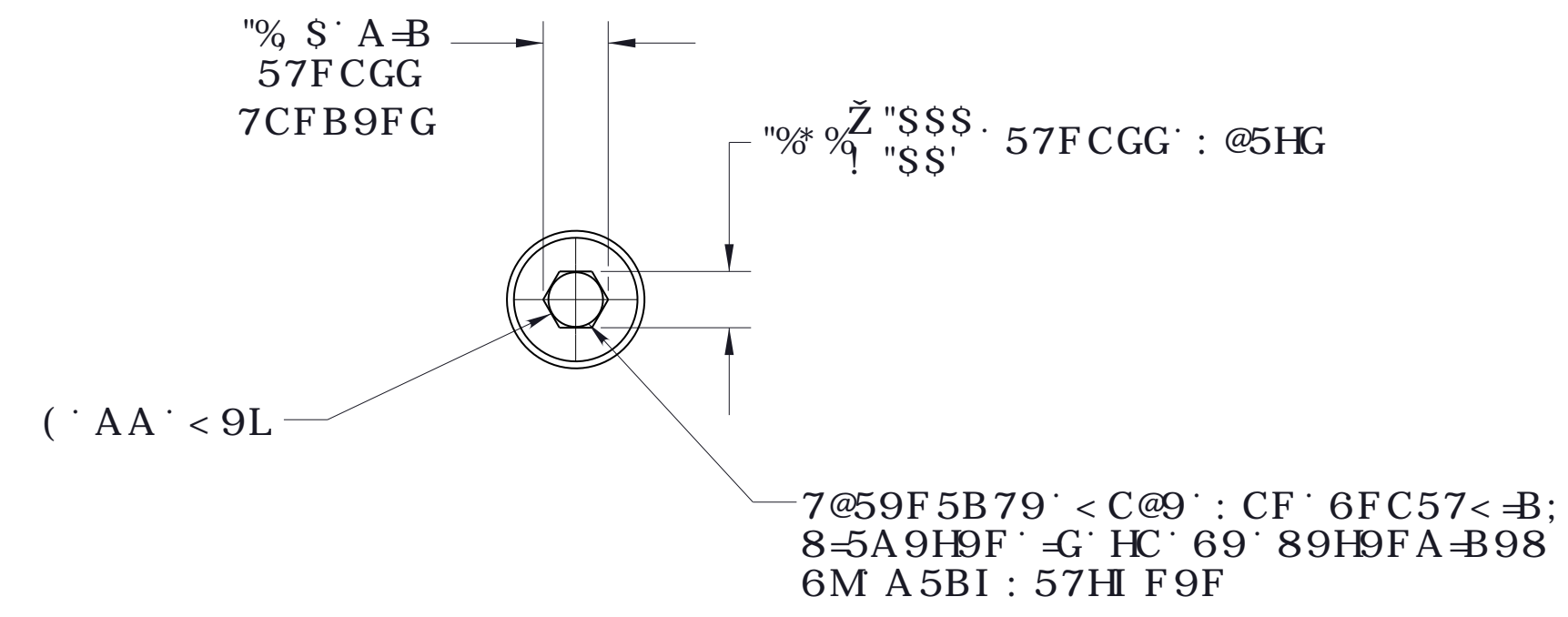
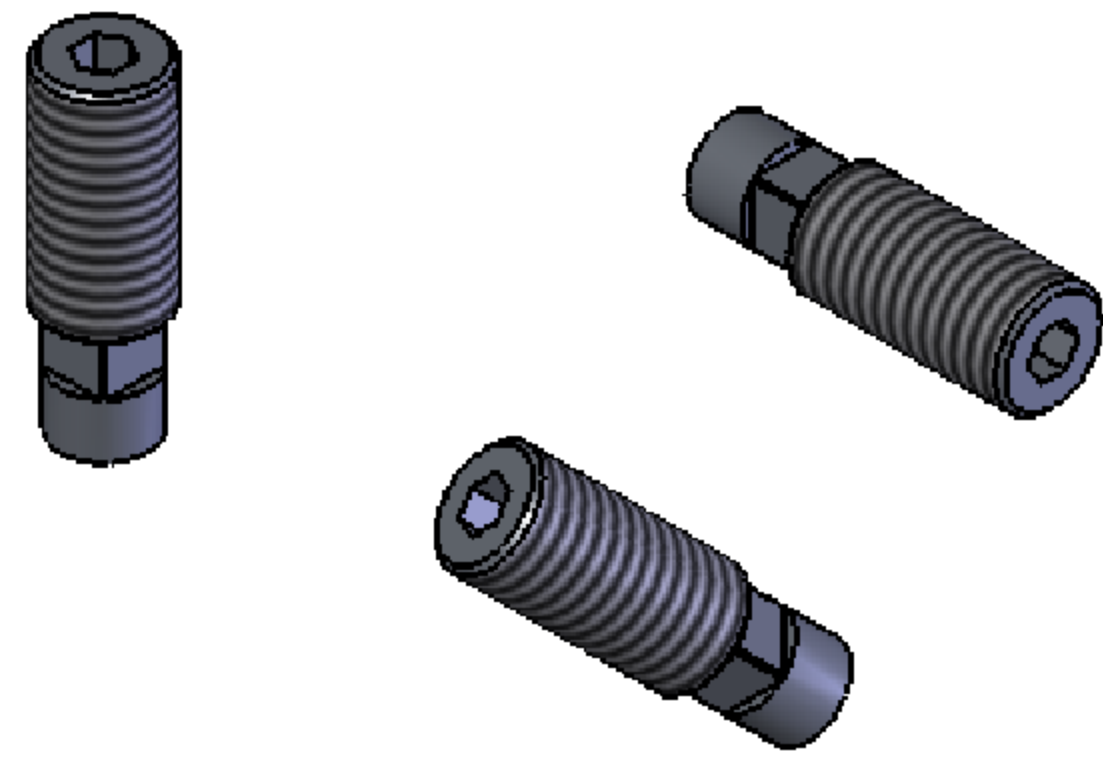

G97HCB : 5! 5

BCH9G.

%' A5H9F=5@' ( %' GH5=B@9GG' GH99@z' < 95H HF95H98' 5B8' 7C@8  
 ' : : -B-G< 98' HC' FC7?K9@@@ f7fi &' ! ' &'

HTORHCVTI WGO<  
 " VJ RFFCY RT' EQPVCIFURHETO CVKOP"  
 HROHCVTI WOPPO' X CI' OCEI RHC'  
 EQO ROPQVULWRECH' TGRQF MEVRP.  
 FRESORHCVTI WROGRIJ RFFCY RT' QP'U G'  
 RHHTO CVKOP' EQPVCIF' 3 GIOR'  
 RUCZRI GAIN' RTQJ RORGF' ZEGREVCUP' Y CI' "  
 OCE' OVA GTI' RUCI' FEGVOR'S' TRORHCVTI"  
 TR J VITGUEXGF' TR' POY' Y CI' OCEI RHC'  
 EQO ROPQVULWRE

SHKDR: 46 PP EDOO PRXQWO P43   183 WKG1	<b>NEWWAY</b> air bearings
COVM9 ? 7G C#SD9 %#& (#&SS* LWSOIHK9	
RTOS RHD ONTF GMRK 96/ DLR L W	GDWS SOD#59
ADD#J #KK R6WOD DCFDR 138' 1353	DVN: MN: CVF: MN: G, S% 6% 6